

RCLDR-DS550-4U-A

Double Section Wall Mount Cabinet Data Sheet



Description

Designed to house rack mount equipment for cabling, telecommunications, IT, industrial and home installations, RCLDR-DS550-4U-A series is supplied assembled-packed, which eases access to the installation site while reducing logistics costs and providing greater protection during transit.

- Toughened glass front door
- Reliable and rigid construction ensure max 60KG static loading capacity

RCLDR-DS550-4U-A series wall mounted cabinet is of perfect structure, and extremely easy for assembling.

Key Features

Top Cover with Fans (Optional)

- 120mm*120mm fans can be preinstalled on the top cover

Removable Side Panel

- Removable side panel simplifies your installation of accessories and monitoring of IT Equipment

Reinforcing Triangle Metal in the Corner

- Reinforcing triangle metal in each corner to make the structure of the rack more solid

Easy Cable Entry

- Cable entry on both of top cover and bottom panel
- Back side with easily punched cable entries

WB-DS Series Cabinet - Components

Wall Mounted Cabinet (Double Section)

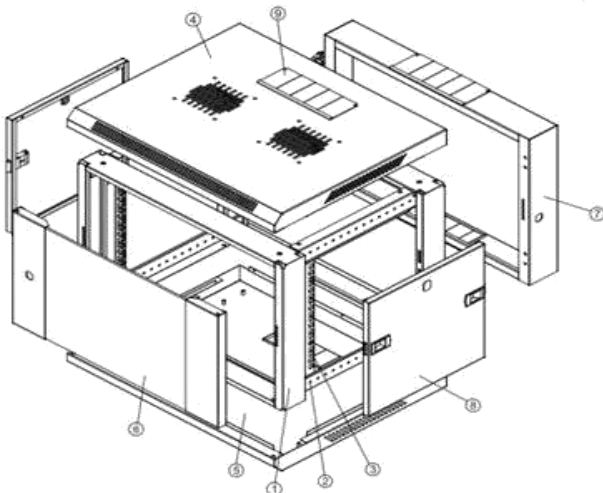

S/N	Specification	Quantity
1	Frame	2
2	Horizontal bracket	4
3	Vertical rail	4
4	Top cover	1
5	Bottom panel	1
6	Front door	1
7	Rear swing frame	1
8	Side panel	2
9	Cable entry	1

Main Dimension

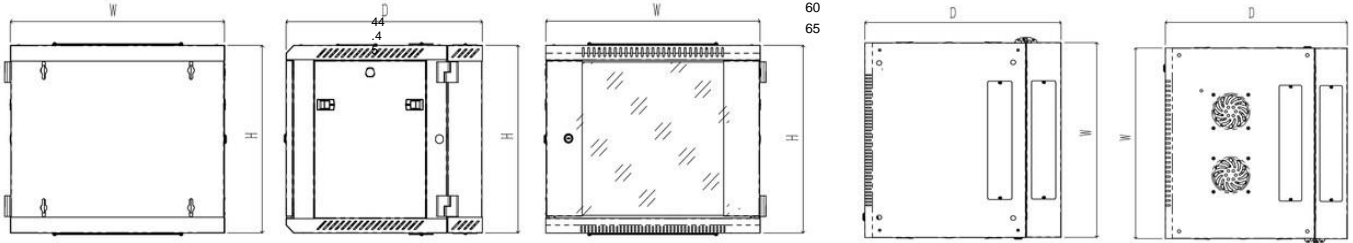

Optional Doors

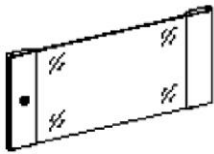

Door: Tempered glass
Lock: Small Round

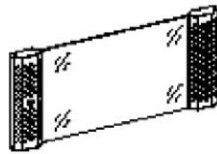

Door: Tempered glass with vented holes
Lock: Small Round

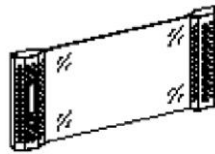

Door: Tempered glass with vented holes
Lock: Spring

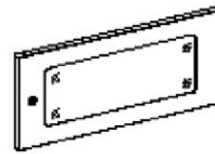

Door: Tempered glass
Lock: Small Round



Door: Solid Iron
Lock: Small Round

Part Number Builder

Part Number Example		Description						
RCLDR-DS5504U-A								
W	B	D	S	6	5	09	0	B
			Product Code	600mm (W)	550mm (D)	04U Capacity	Door Style	Color

Specification

Part Number	Capacity (U)	Width	Depth	Assembled Height	Box Dimension
RCLDR-DS6504U-A	4	600 mm	550 mm	300 mm	620x530x320mm

Note: Hardware: 10 sets cage nuts, B for Black, G for Grey

Optional Accessories

- Fixed Shelf
- Sliding Shelf
- Cable Management
- Cooling Solution
- Air Flow Management
- PDU

The dimensions and specifications in this document are for reference purposes only and are subject to change without notice.

Consult www.leadersystems.com.au for the latest dimensions and design specifications.

